

DUAL SLIMLINE BALL NON-RETURN VALVE



DUAL's Slimline Valve's heart is a reinforced Urethane or Rubber ball. The unique design of the valve allows free movement of the ball. The ball lifts completely out of the flow without any interference. As the pump stops, the ball falls and positively locates the seat due to its own weight and back pressure of the liquid. This results in drop-less sealing.

PRODUCT SPECIFICATION

SIZE RANGE: 50mm - 600mm
Larger sizes on request.

OPERATING TEMPERATURES: -10°C to +80°C.

BODY TYPES: Ball foot valve.
Ball non-return valve.

PRESSURE RATINGS: See table below.

BALL MATERIAL: Steel core, Urethane or Rubber coated.

FEATURES

- Perfect sealing.
- Low head losses.
- Non clogging, self cleaning ball.
- Minimum back pressure for tightness 0.3 to 0.5 Bar.
- Removable bonnet for cleaning or replacing of ball.
- Maintenance free.
- Full bore.
- Silent, non-slam, reduces pipe hammer.
- Fabricated valves face-to-face can be altered to suit different types of valve face-to-face dimensions.
- Simple construction - one moving part.

WORKING PRESSURE	PN10	PN16	PN25
SHELL TEST PRESSURE	1.5MPa	2.4MPa	3.7MPa
SEAL TEST PRESSURE	1.1MPa	1.76MPa	2.5MPa

For higher pressure, please consult the factory.

CAST STEEL 100MM "CVB SFFV" FOR WATER AND SEWAGE



“SFFV” REPLACE SWING-CHECK VALVES

INSTALLATION

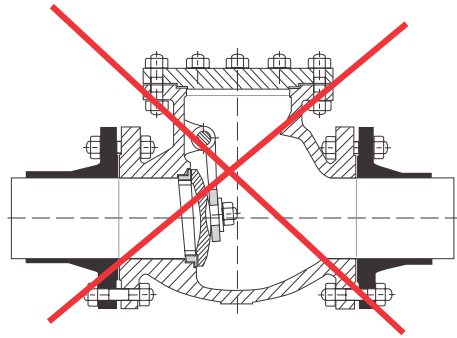

Vertical Installation



Horizontal Installation

OUTLINE DIMENSIONS & SPECIFICATION

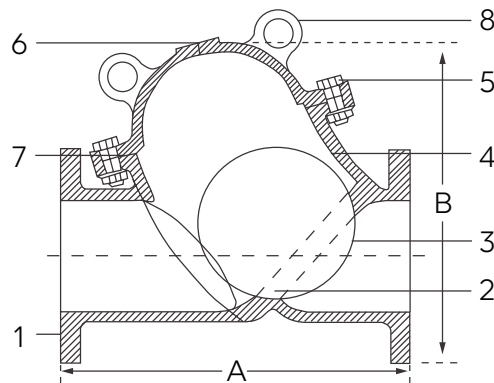

CAST STEEL 100MM “CVB SFFV” FOR WATER WORKS



PART	DESCRIPTION
1	Body Carbon Steel / Cast Steel / Stainless Steel
2	Body Seat Abrasion Resistant AR Steel, S.S., Urethane or Rubber
3	Ball Aluminium Insert, W/Urethane or Rubber Coating
4	Valve Body Lining Rubber, Urethane or Ceramic
5	Bolts and Nuts Cadmium Plated Steel
6	Paint Epoxy Powder Coated, Rilsan Lined or Painted to Custom Spec
7	Body Gasket 'O' Ring
8	Lifting Lug Carbon Steel / Cast Steel / Stainless Steel

PRESSURE DROP DIAGRAM

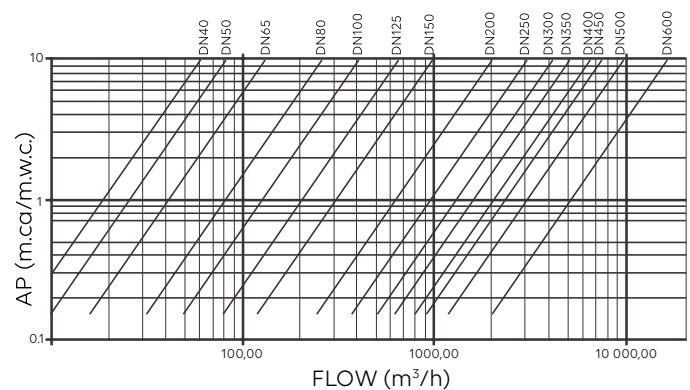

DIMENSIONS AND WEIGHTS

SIZE (mm)	A FACE TO FACE DIMENSIONS				B	WEIGHT (kg)	KV (m²/H)
	SABS	AS4794	DIN320-F6	ANSI B16-10			
50	230	200	200	203	250	30	81
80	305	260	260	241	300	50	255
100	355	330	300	292	330	80	400
125	344	344	350	330	350	85	645
150	445	410	400	356	400	90	970
200	535	540	500	495	500	100	2000
250	635	640	600	622	600	150	3050
300	760	700	700	698	750	300	4150
350	865	830	800	787	900	350	5150
400	865	920	900	914	1000	500	6600
450	978	978	978	978	1200	550	8258
500	1067	1067	1067	1067	1300	700	11850
600	1295	1295	1295	1295	1500	1100	16140



CORPORATE HEADQUARTERS: 166 ROTTERDAM ROAD (CNR ROTTERDAM ROAD & ANTWERP STREET) APEX, BENONI, GAUTENG, SOUTH AFRICA
 PO BOX 12520, BENORYN 1504
 TEL: +27 11 422 4326/7
 FAX: +27 11 421 7842
 EMAIL: SALES@DUALVALVES.COM